

ANALYTICAL EQUIPMENT FOR



ECOLOGY AND POWER INDUSTRY

# MAPK-303E DISSOLVED OXYGEN METER

*Operation Manual*



АЯ 74

Nizhny Novgorod  
2010

VZOR will appreciate any suggestions and comments aimed at product quality improvement.

If you have any trouble with the instrument performance, please contact us in writing or by phone.

Postal address: 603106, Russia, Nizhny Novgorod, PB 253

Telephone: + 7 (831) 229-65-67, 412-29-40

E-mail: [market@vzor.nnov.ru](mailto:market@vzor.nnov.ru)

Website: [www.vzornn.com](http://www.vzornn.com)

# CONTENTS

1 DESCRIPTION AND OPERATION .....	4
1.1 Purpose.....	4
1.2 Basic characteristics .....	4
1.3 Technical data.....	6
1.4 Analyzer components .....	7
1.5 Design and operation.....	7
1.6 Measuring instruments, tools and appliances.....	27
2 INTENDED USE .....	28
2.1 Operating limitations .....	28
2.2 Safety precautions .....	28
2.3 Analyzer pre-starting procedures.....	28
2.4 Measurement procedure.....	40
2.5 Inspection of condition .....	42
2.6 Troubleshooting .....	42
3 MAINTENANCE.....	49
4 DELIVERY SET .....	49
ATTACHMENT A. SOLUBILITY OF 100%-HUMIDITY AIR OXYGEN IN DISTILLED WATER DEPENDING ON TEMPERATURE .....	50

# 1 DESCRIPTION AND OPERATION

## 1.1 Purpose

### 1.1.1 Product name and identification

MAPK-303E dissolved oxygen analyzer

TU 4215-029-39232169-2008.

Analyzer application: measurements of dissolved oxygen mass concentration (DOC) and temperature of surface and waste water, drinking water, in fish farms, flow processes, training processes and ecology.

### 1.1.2 Type of analyzer:

- amperometric;
- with external reference voltage;
- with a single sensitive element;
- with liquid crystal display plotter;
- with automated temperature compensation;
- with DOP-303E flow submersible probe;
- with automatic calibration when the probe is located in oxygen environment (air) at a temperature plus 15 to plus 35 °C;
- with automatic atmospheric pressure correction on calibration.

## 1.2 Basic characteristics

1.2.1 By resistance to climatic load, the analyzer version belongs to B4 group according to GOST 12997-84.

1.2.2 By resistance to mechanical action, the analyzer version belongs to L1 group according to GOST 12997-84.

1.2.3 By resistance to atmospheric pressure, the analyzer version belongs to P1 group according to GOST 12997-84 (atmospheric pressure from 84 to 106.7 kPa).

### 1.2.4 Parameters of analyzable water:

- temperature, °C ..... 0 to plus 50;
- pressure, MPa, max ..... 0.2;
- salt content, ppt ..... 0 to 40;
- pH ..... 4 to 12;
- water flow velocity relative to probe membrane, cm/s ..... 5.

### 1.2.5 Permissible concentrations of ingredients not to be measured:

- dissolved ammonia, ppm, max ..... 40.0;
- dissolved phenol, ppm, max ..... 0.2;
- dissolved hydrogen sulphide, ppm, max ..... 0.5;
- dissolved chlorine, ppm, max ..... 4.0.

### 1.2.6 Operating conditions:

- ambient air temperature, °C ..... plus 1 to plus 50;
- ambient air relative humidity at a temperature of plus 35 °C and below without moisture condensation, %, max ..... 80;
- atmospheric pressure, kPa (mm Hg) ..... 84.0 to 106.7  
(630 to 800).

1.2.7 The analyzer is calibrated against air of 100 % humidity at a temperature plus 15 to plus 35 °C.

1.2.8 The analyzer is powered up from a self-contained DC power supply with voltage from 2.2 to 3.4 V.

1.2.9 Analyzer power requirements at rated supply voltage of 2.8 V, mW, max:

- with display illumination off ..... 20;
- with display illumination on ..... 300.

1.2.10 The analyzer retains in-spec characteristics after dry cell replacement and calibration.

1.2.11 Dimensions and weight of analyzer components are shown in Table 1.1.

*Table 1.1*

Identification of components	Maximum dimensions, mm	Max weight, kg
CU-303 convertor unit BP47.01.000	65×130×28	0.12
DOP-303E oxygen probe BP47.02.000-01 (w/o cable)	∅14×115	0.1

1.2.12 Conditions of transportation in shipping crates under GOST 12997-84:

- temperature, °C ..... minus 20 to plus 50;
- air relative temperature at 35 °C, % ..... (95 ± 3);
- sinusoidal vibration of 5-35 Hz frequency, shift amplitude of 0.35 mm in direction shown by the "Top" sign on a crate.

### 1.2.13 Safety requirements

1.2.13.1 Average time between failures, hour, min ..... 20000.

1.2.13.2 Mean recovery time, hour, max ..... 2.

1.2.13.3 Analyzer average life span, years, min ..... 10.

1.2.13.4 According to GOST 14254-96 the convertor unit protection level ensured by enclosure is IP65.

### 1.3 Technical data

1.3.1 Range of dissolved oxygen concentration measurements at analyzable fluid temperature of 20 °C, ppm ..... 0 to 10.

The upper limit of DOC measurement range shall be governed by the analyzable fluid temperature and is shown in Table 1.2.

Table 1.2

t, °C	0	5	10	15	20	25	30	35	40	45	50
DOC, ppm	32,16	28,09	24,84	22,18	20,00	18,17	16,63	15,38	14,10	13,05	12,08

1.3.2 The range of analyzer allowable basic absolute accuracy when measuring DOC at analyzable fluid temperature of  $(20.0 \pm 0.2)^\circ\text{C}$  and ambient air temperature of  $(20 \pm 5)^\circ\text{C}$ , ppm .....  $\pm(0.050 + 0.04C)$ , where C hereinafter is DOC measured value in ppm.

1.3.3 The range of analyzer allowable complementary absolute accuracy when measuring DOC governed by changes in analyzable fluid temperature per each  $\pm 5^\circ\text{C}$  deviation from normal temperature  $(20.0 \pm 0.2)^\circ\text{C}$  within the operating temperature range from 0 to plus 50 °C, ppm .....  $\pm 0,012C$ .

1.3.4 The range of analyzer allowable complementary absolute accuracy when measuring DOC governed by changes in analyzable fluid temperature per each  $\pm 10^\circ\text{C}$  deviation from normal temperature  $(20 \pm 5)^\circ\text{C}$  within the operating temperature range from plus 1 to plus 50 °C, ppm .....  $\pm(0.002 + 0.002C)$ .

1.3.5 Limits of the analyzer allowable additional absolute error in DOC measurement at surplus pressure of analytical environment up to 0.2 MPa, ppm.....  $\pm 0.1C$ .

1.3.6 The range of analyzer allowable absolute accuracy when measuring DOC at analyzable fluid temperature coincident with calibration temperature lying within the temperature range from plus 15 to plus 35 °C and at ambient air temperature of  $(20\pm 5)^\circ\text{C}$ , ppm .....  $\pm(0.050 + 0.04C)$ .

1.3.7 Measuring range of analyzable fluid temperature, °C ..... 0 to plus 50.

1.3.8 The range of analyzer allowable basic absolute accuracy on measuring analyzable fluid temperature at ambient air temperature of  $(20\pm 5)^\circ\text{C}$ , °C .....  $\pm 0.3$ .

1.3.9 The range of analyzer allowable complementary absolute accuracy on measuring analyzable fluid temperature governed by changes in ambient air temperature per each  $\pm 10^\circ\text{C}$  deviation from normal  $(20 \pm 5)^\circ\text{C}$  temperature within the operating range from plus 1 to plus 50 °C, °C .....  $\pm 0.1$ .

1.3.10 Limit of the permissible value of the analyzer readout setting time  $t_{0,9}$  in DOC measurement, minute ..... 1.

1.3.11 Limit of the permissible value of the analyzer readout setting time  $t_y$  in DOC measurement, minute ..... 2.

1.3.12 Limit of the permissible value of the analyzer readout setting time  $t_{0,9}$  in analyte temperature measurement, minute ..... 1.

- 1.3.13 Limit of the permissible value of the analyzer readout setting time  $t_y$  in analyte temperature measurement, minute ..... 3.
- 1.3.14 Instability of analyzer readings on DOC measurements for an 8-hour period, ppm, max .....  $\pm (0.025 + 0.02C)$ .
- 1.3.15 When connected to a PC through a USB jack, the analyzer communicates with the PC.

## **1.4 Analyzer components**

MAPK-303E dissolved oxygen analyzer is composed of:

- CU-303 convertor unit;
- DOP-303E oxygen probe with a connecting cable 5 m long.

## **1.5 Design and operation**

### **1.5.1 Analyzer general data**

MAPK-303E dissolved oxygen analyzer is a small-size microprocessor instrument used to measure mass concentration of oxygen dissolved in water (DOC), as well as temperature of water.

Measured temperature and DOC values in ppm or ppb (depending on the DOC value) are shown on a digital liquid crystal display (hereafter “display”). The least significant digit on measuring temperature is 0.1 °C. The least significant digit on measuring DOC is 0.1 ppb.

The analyzer makes it possible to enter the measurement results in a scratchpad.

The analyzer is calibrated against atmospheric air of 100 % humidity in view of atmospheric pressure at the time of calibration.

To use atmospheric pressure data in analyzer calibration against atmospheric air, a built-in atmospheric pressure sensor is used.

**Note** – The analyzer can be calibrated using State Standard Specimens of Control Gas Mixtures with known content of oxygen in % vol. or against the solution with known DOC in ppb.

The analyzer can read DOC in saturation percentage with the least significant digit of 0.01 %.

### 1.5.2 Analyzer operating principle

To measure water-dissolved oxygen content, the analyzer is furnished with amperometric probe working as a closed polarographic cell. Electrodes are submerged in the internal electrolyte solution which is isolated from the measurable fluid by a membrane permeable for oxygen and impermeable for the liquid and water vapors. Oxygen from analyzable fluid penetrates through a membrane and diffuses through a thin electrolyte layer between electrodes and the membrane and undergoes an electrochemical reaction on the cathode surface which is polarized by external voltage between electrodes. In this case the probe generates a DC signal which at constant temperature is proportional to concentration of oxygen dissolved in the controllable fluid.

To measure temperature and automatically compensate for temperature dependence of the signal from the oxygen probe, the analyzer is furnished with a temperature sensor (platinum thermal resistor). A signal from the temperature sensor goes to the ADC input.

ADC converts signals from the oxygen and temperature sensors into codes fed to the microcontroller.

The microcontroller shall process the codes and shows data on the liquid crystal display plotter.

### 1.5.3 Analyzer design

The analyzer is shown in Fig. 1.1a.

The convertor unit 1 enclosed in a plastic tight casing, transforms signals from the oxygen probe 2 into displayable measurement results and transmits data to a PC.

The convertor unit front panel carries:

- a display screen 3 to show measured DOC and temperature, dry cell charge, date, time and navigate in the menu; and
- keys 4.

The convertor unit rear panel bears a cover of the dry cell compartment.

The upper end face of the convertor unit carries:

- a tight oxygen probe 2 cable entry 5; and
- a jack 6 for connection to PC.

Fig. 1.1b shows the design of the oxygen probe.



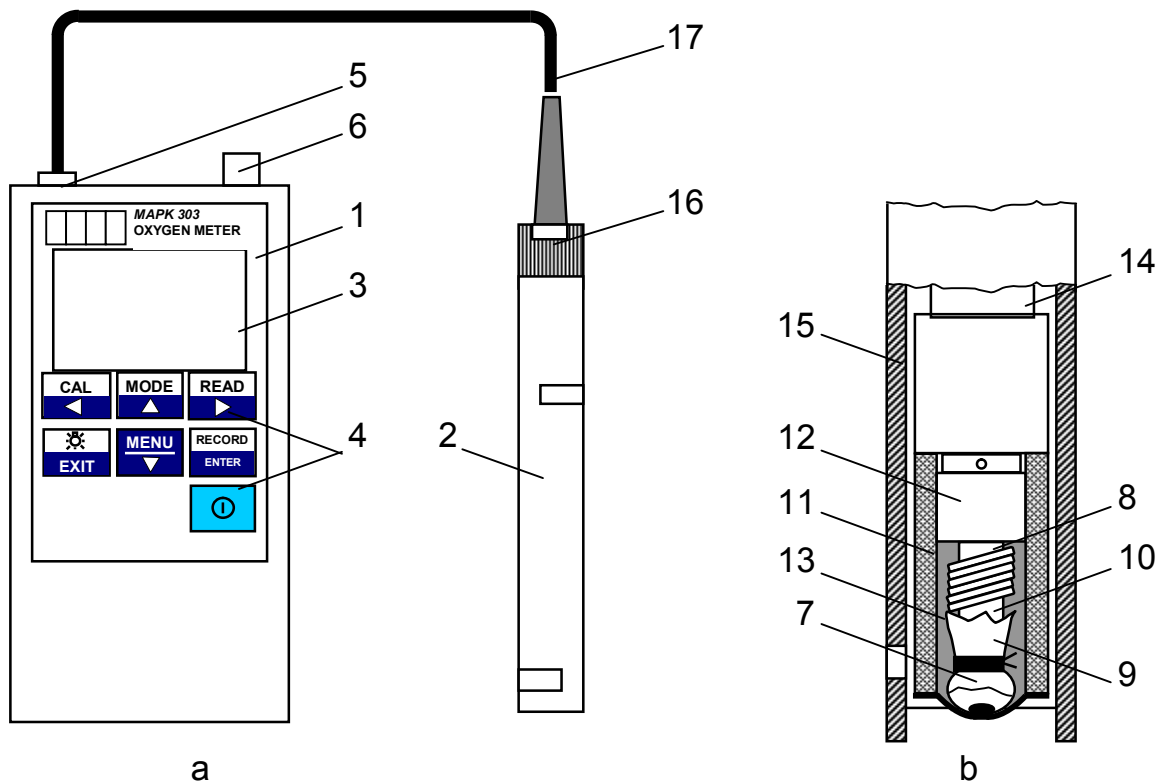


Fig. 1.1

Basic components of the probe include a platinum cathode 7 and a silver anode 8. The cathode 7 bears a Teflon film 10 secured by nylon threads 9. The membrane and the rubber bushing make the membrane assembly 11 put onto the bushing and filled with electrolyte 13. The temperature sensor is nested in the casing 14. The protective bushing 15 covers the probe electrode member and is thread-joined with the cable sleeve 16.

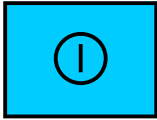
The cable 17 connects the probe electrode member to the convertor unit.

#### 1.5.4 Functions of keys on the convertor unit front panel

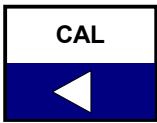
The analyzer uses non-locking keys.

The symbols on the light key space show their functions in DOC measurement mode.

The symbols on the dark key space reflect their functions when working with the scratchpad and display menu.

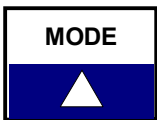


The blue key is used to turn on and off the analyzer. It is to be held depressed for 2 s.



The key is used:

- in measurement mode – to shift to the analyzer calibration mode. It is to be held depressed for 0.5 s;
- when working with the scratchpad and display menu – to move in a line leftward.



The key is used:

- in measurement mode – to select the mode of DOC measurement in ppm (ppb) or saturation %. It is to be held depressed for 0.5 s;
- when working with the scratchpad and display menu – to move in a line upward.



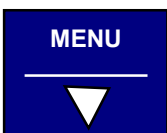
The key is used:

- in measurement mode – to move from measurement mode to the mode of data view entered into the scratchpad. It is to be held depressed for 0.5 s;
- when working with the scratchpad and display menu – to move in a line rightward.



The key is used:

- in measurement mode – to turn on and off display illumination;
- when working with the scratchpad and display menu – to exit from scratchpad and menu displays.



The key is used:

- in measurement mode – to enter the display menu. It is to be held depressed for 0.5 s;
- when working with the scratchpad and display menu – to move in a line downward.



The key is used:

- in measurement mode – to enter data into the scratchpad. It is to be held depressed for 0.5 s;
- when working with the scratchpad and display menu – to confirm selected parameters and operating modes.

## 1.5.5 Measurement mode

### 1.5.5.1 Measurement displays

Display screens in the mode of DOC measurement in ppb and in ppm are shown in Fig. 1.2 and 1.3, respectively.

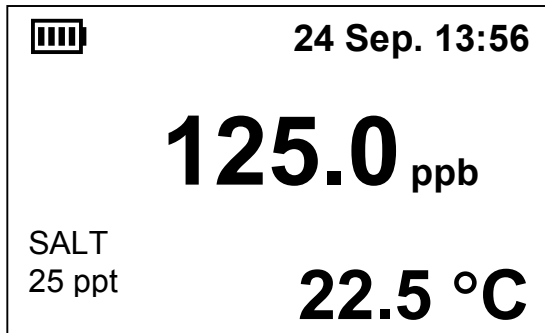


Fig. 1.2

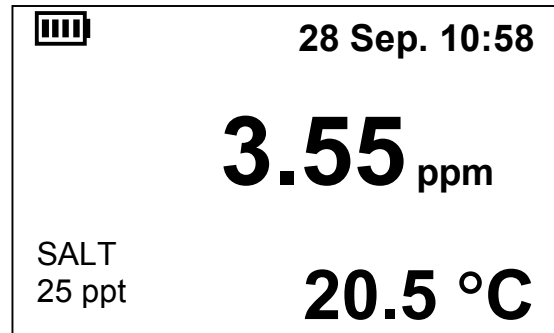


Fig. 1.3

Display screen in the mode of DOC measurement in saturation % is shown in Fig 1.4.

Figures may be different.

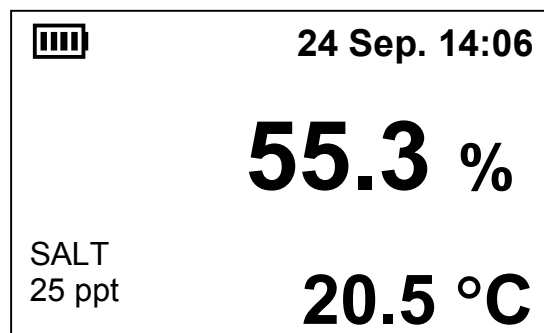




Fig 1.4

The display screen shows the following:

- dry cell charge. The number of bars in the symbol shows the dry cell charge level as follows: one bar – 25 %, two bars – 50 %, three bars – 75 %, four bars – 100 %;
- date (day and month) and current time. The date and time are set up as described in 1.5.8 (menu option **DATE TIME**);
- measured DOC value. To move from the mode of DOC measurement in ppb and ppm to the mode of DOC measurement in saturation % the key  is used;
- temperature of analyzable fluid, °C;
- the value of salt content in the analyzable fluid entered by a user.




Display illumination is turned on and off using key  .

According to 1.5.8 (menu option **ADDITIONAL SETTINGS**), a time period in seconds when illumination is on if any of the keys is depressed, may be set up.

If the display shows intermittent messages or dashes rather than DOC or temperature values and the audible overload signal is on, refer to 1.5.9.

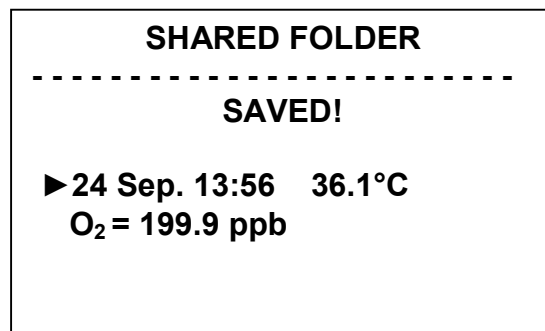
### 1.5.6 Measurement results saving in the scratchpad

To enter measurement results in the scratchpad, depress  key for 0.5 s.

The display shall show the list of folders made by a user including **SHARED FOLDER**. Using  and  keys move the cursor against the folder required, for instance, **SHARED FOLDER**, and depress the key .

If there are no folders made by a user, data shall be entered in the **SHARED FOLDER**.

The display shown in Fig. 1.5 shall appear for 2 s, and then the analyzer shall change the current mode to the measurement mode.




*Fig. 1.5*

The selected folder shall contain the following:

- date and time of measurement;
- temperature of analyzable fluid;
- DOC value measured in ppb (in ppm) or in saturation % according to the selected operating mode.




If the pad is filled to capacity, on entering data the display shall show the message "SAVING IS IMPOSSIBLE, SCRATCHPAD IS OVERFILLED".



### 1.5.7 View of entries in the scratchpad

To view entries, depress  key for 0.5 s in the measurement mode.

The display **LIST OF FOLDERS** shall show the list of folders made by a user. The **SHARED FOLDER** comes first in the list. The other folders shall appear in the order they have been made. The intermittent cursor shall automatically appear against the folder that has been requested last.

If space on the screen is not enough for the whole list, a scroll bar shall come up on the right side of the screen. The dark color square on the scroll bar shall show an approximate location of the visible part of the list relative to the whole list.



Using the keys  and  move the cursor to the folder needed and press the key .

If the keys  and  are depressed for more than 1 s, the list shall be automatically scrolled in the respective direction.

If there are no folders made by the user, **SHARED FOLDER** shall automatically open.

The display shall show measurements saved in the folder according to date and time. The intermittent cursor shall automatically move to the last entry.

If space on the screen is not enough for measurement data, arrows at the top and bottom of the scroll bar shall show where (at the top or bottom of the list) the measurement data invisible on the screen are to be found.

To scroll the data list use the keys  and . If the keys are depressed for more than 1 s, the list shall be automatically scrolled in the respective direction.

Since on scrolling the list it moves itself, the cursor shall always remain against the message shown on the screen.

If entry in the pad has been made in the mode of DOC measurement in ppm, the display shown in Fig. 1.6 shall come up.

If entry in the pad has been made in the mode of DOC measurement in ppb, the display shown in Fig. 1.7 shall come up.

If entry in the pad has been made in the mode of DOC measurement in saturation %, the display shown in Fig. 1.8 shall come up.

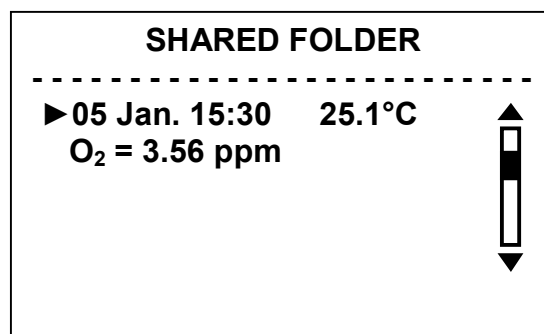


Fig. 1.6

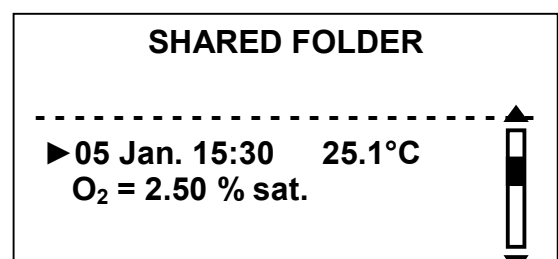
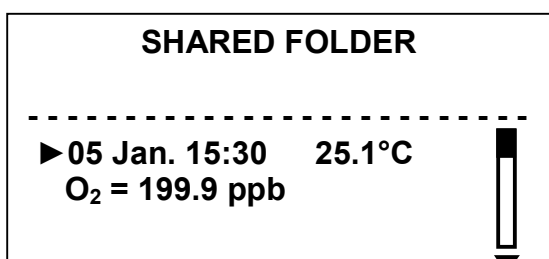






Fig. 1.7


Fig. 1.8

If there are no entries in the folder, the respective message shall come up. If the cursor is moved to the message needed and key  is depressed, the display shown in Fig. 1.9 shall come up. The entry shall open and memorized DOC value shall be additionally recalculated in the units different from the memorized units. Also, memorized salt content shall be shown.


<b>05 Jan. 15:30</b>	<b>25.1 °C</b>
<b>O<sub>2</sub> = 199.9 ppb</b>	
<b>(2.50 % sat.)</b>	
<b>SALT 25 ppt</b>	
<b>▶EXIT</b>	
<b>DELETE RECORD</b>	

Fig. 1.9

Using either of the keys  and  move the cursor against **DELETE RECORD** and depress the key . Data on the screen shall be deleted. The "**RECORD DELETED!**" message shall appear on the screen for 2 s.


If the cursor is moved against **EXIT** and the key  is depressed, the displays shown in Fig. 1.6-1.8 come up.

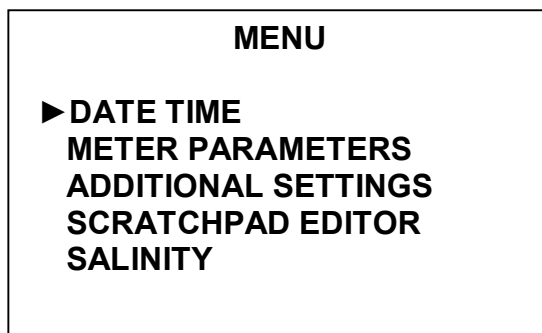
Pad shall be edited including clearing of folders, making new folders, folder deletion as described in 1.5.8 (**SCRATCHPAD EDITOR** menu command).

To go over to the measurement mode or exit from any display and return to the previous display, press the key .

### 1.5.8 MENU mode



The analyzer parameters shall be viewed and changed in the **MENU** mode.


To move from the measurement mode to the **MENU** mode, depress the key  for 0.5 s. **MENU** display is shown in Fig. 1.10.



*Fig. 1.10*

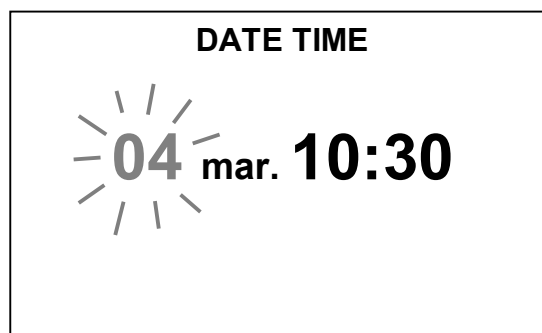
To exit from any display of **MENU**, depress the key .

To move the marker "►" in the menu, the keys  and  are used. If these keys are depressed for more than 1 s, the cursor shall automatically start moving in the respective direction.

To select the menu command needed, move the marker to the entry and press the key .



#### 1.5.8.1 ► DATE TIME menu command

► **DATE TIME** is the menu command to enter date and time. The **DATE TIME** display is shown in Fig. 1.11.



*Fig. 1.11*

Date and time shall be entered separately in any order: date, month, hours, and minutes.

Moving to the left and to the right is carried out using the keys , . In this case the parameter that may be changed starts flickering.

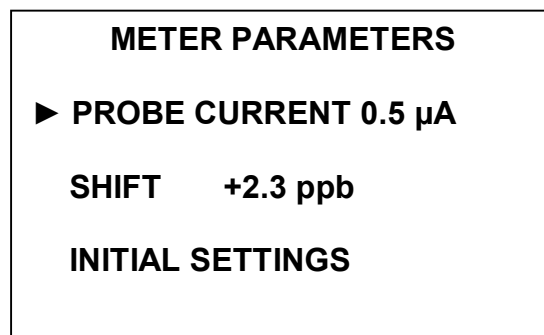
Parameters shall be changed using the keys , .

In open **DATE TIME** display the clock stops, and it is actuated on exit from this display.

### 1.5.8.2 ► **METER PARAMETERS** menu command

► **METER PARAMETERS** is the menu command to view parameters of the electrode system.

On selection of this menu command, the display shown in Fig. 1.12 shall come up.




*Fig. 1.12*

The display shall show the following parameters of the probe DOC measurement channel:

- probe current in µA measured on calibration against atmospheric air and reduced to temperature of 20 °C and normal atmospheric pressure of 101.325 kPa ("**PROBE CURRENT**");
- probe readings in ppb with the probe located in the "zero" solution on calibration ("**SHIFT**").

Parameters of the probe in good working condition shall lie in the following ranges:

- "**PROBE CURRENT**" – from 1 to 10 µA;
- "**SHIFT**" – from minus 2.9 to plus 2.9 ppb.

If the cursor is moved against "**PROBE CURRENT**" and key  is depressed, the display shall show the time of the previous analyzer calibration as show in Fig. 1.13.



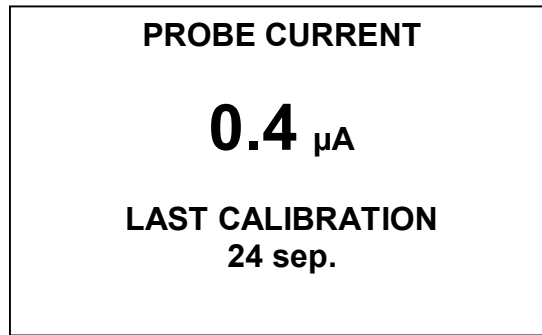


Fig. 1.13

If the cursor is moved against SHIFT and the key 

RECORD
ENTER

 is depressed, the display in Fig. 1.14 with the flickering number shall come up.

Using the keys 

MENU
▼

 and 

MODE
▲

 set the shift value required. Shift setting makes it possible to reach the analyzer zero readings holding the probe in a fresh "zero" solution for at least 40 min. The figure changes in the range from minus 2.9 to plus 2.9 ppb.

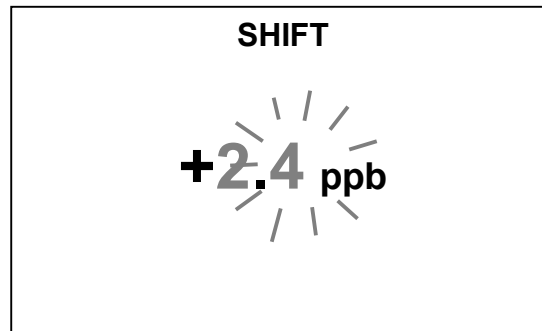


Fig. 1.14

Depress the key 

RECORD
ENTER

 and "**SAVED!**" message shall appear for 2 s at the screen bottom, and the analyzer shall return to the **METER PARAMETERS** display.

If the cursor is moved against the **INITIAL SETTINGS** command, and the key 

RECORD
ENTER

 is depressed, the display shown in Fig. 1.15 shall come up.

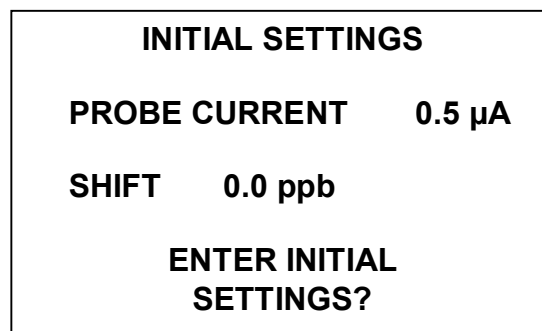

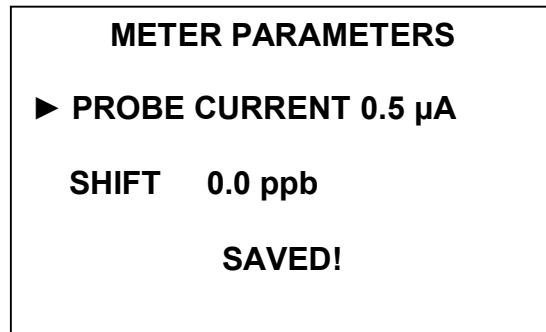


Fig. 1.15

Depress the key  for 2 s and the display shown in Fig. 1.16 shall come up, and the analyzer shall change the current display to the **METER PARAMETERS** display.

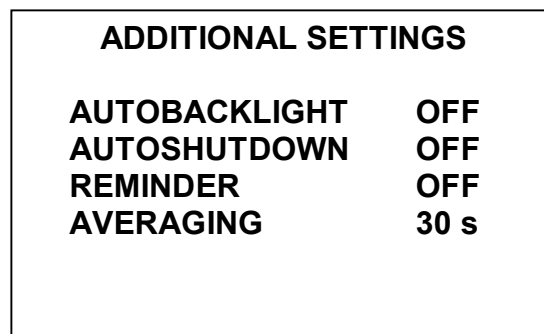


*Fig. 1.16*

### 1.5.8.3 ► **ADDITIONAL SETTINGS** menu command

► **ADDITIONAL SETTINGS** is the menu command used to set the time of automatic deactivation and time of automatic illumination as well as to turn on or off the option reminding about calibration.

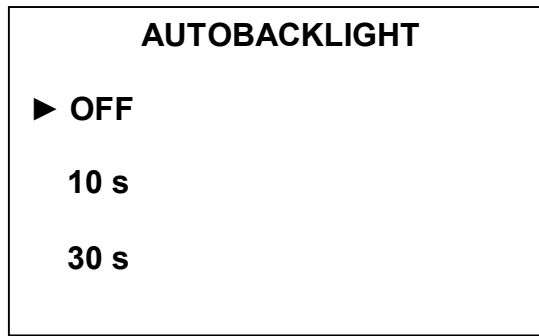
On selection of this menu command, the display shown in Fig. 1.17 shall come up.



*Fig 1.17*

► **AUTOBACKLIGHT** is the sub-menu command used to set illumination time of 10 s or 30 s once any of the keys is depressed.

On selection of this sub-menu command, the display shown in Fig. 1.18 shall come up.



*Fig. 1.18*

If the cursor is moved against **OFF**, automatic illumination shall not work. Select parameter needed and depress the 

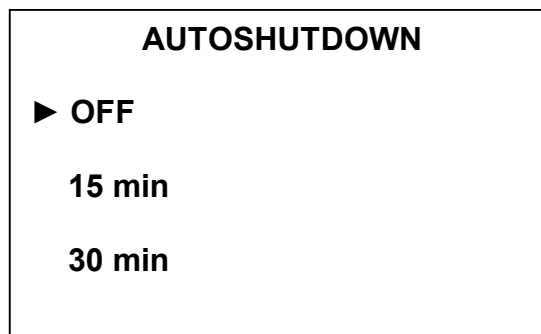
RECORD
ENTER

 key.

**Note** – At supply voltage of 2.4 V and below display illumination does not work.

▶ AUTOSHUTDOWN is the sub-menu command intended to set deactivation time of 15 min or 30 min once any of the keys is depressed.

On selection of this sub-menu command the display shown in Fig. 1.19 shall come up.



*Fig. 1.19*

If the cursor is moved against **OFF**, automatic deactivation shall not work. Select the parameter needed and depress the 

RECORD
ENTER

 key.

▶ REMINDER is the sub-menu command intended to switch off the calibration remind command.

On selection of this sub-menu command, the display shown in Fig. 1.20 shall come up.

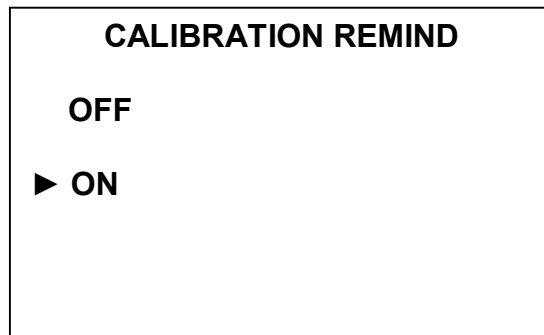


Fig. 1.20

If the cursor is moved against **ON**, and the key **RECORD ENTER** is depressed, on activation of the meter the display shown in Fig. 1.21 shall come up (if a time period after the previous analyzer calibration exceeds 10 days).

On depressing any key the analyzer shall go over to the measurement mode.

If calibration has not been carried out, on next actuation of the analyzer calibration remind shall appear again.

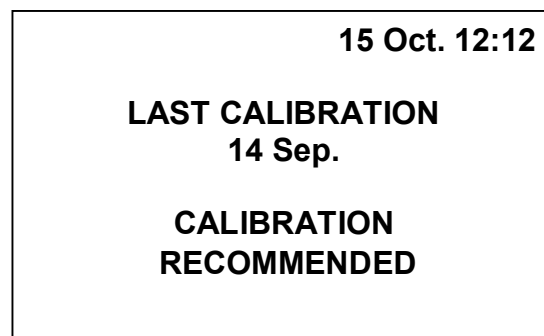


Fig. 1.21

▶ **AVERAGING** is the sub-menu command used to set time for averaging the measured DOC value.

On selection of this sub-menu command the display shown in Fig. 1.22 shall come up.

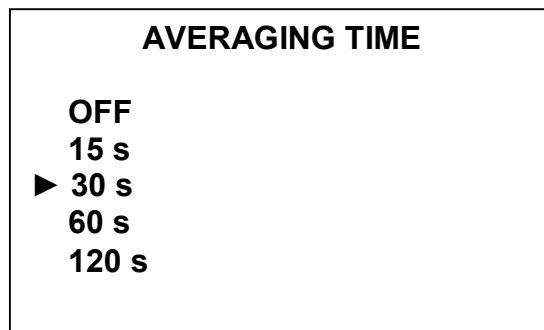



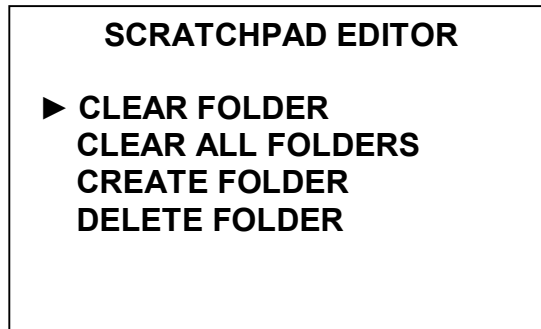
Fig. 1.22

If the cursor is moved against **OFF**, averaging of the measured DOC value shall not work.

Select parameter needed and depress the  key.

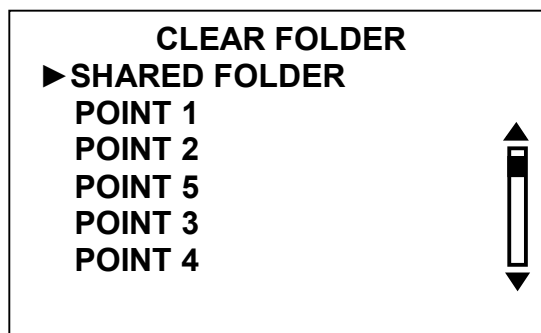
#### 1.5.8.4 ► **SCRATCHPAD EDITOR** menu command

► **SCRATCHPAD EDITOR** is the display shown in Fig. 1.23.




*Fig. 1.23*

1 CLEAR FOLDER display is shown in Fig. 1.24.  
Names of folders may be different.



*Fig. 1.24*

The cursor is always moved to **SHARED FOLDER** first.

To clear a folder with entries, paste it using the cursor and press the key .

The display shall show the name and content of the folder as shown, for instance, in Fig. 1.25.

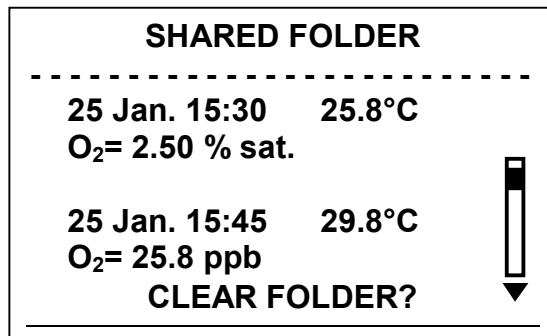


Fig. 1.25

Press the key RECORD  
ENTER. The folder is clear. The display shall show NO RECORDS message for 2 s and the analyzer shall go over to the CLEAR FOLDER display.

The other folders may be cleared in the same manner.

2 CLEAR ALL FOLDERS display is shown in Fig. 1.26.

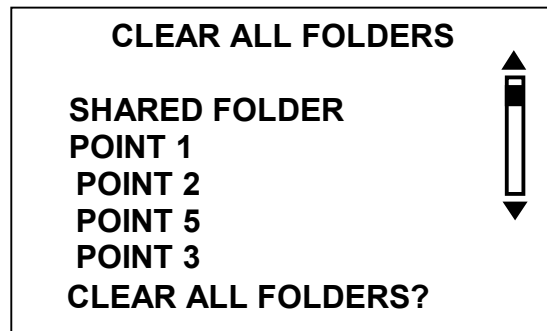


Fig. 1.26

Press the key RECORD  
ENTER. All folders are clear. The display shall show NO RECORDS message for 2 s and the analyzer shall go over to the SCRATCHPAD EDITOR display.

3 CREATE A FOLDER display is shown in Fig. 1.27.

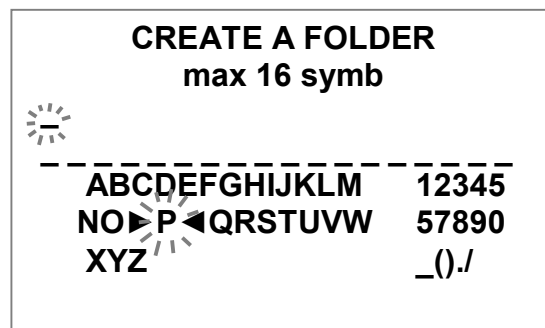







Fig. 1.27

If the pad is filled to capacity, the "CREATION OF NEW FOLDER IS IMPOSSIBLE. DELETE ANY FOLDER" message shall appear on the screen.

To enter the name of a folder, paste any character using the cursor "► ◀". Move the cursor "► ◀" using the , , ,  keys.

Once the key  is depressed, the pasted character shall be entered into the folder name, and the display shown in Fig. 1.28 shall come up.

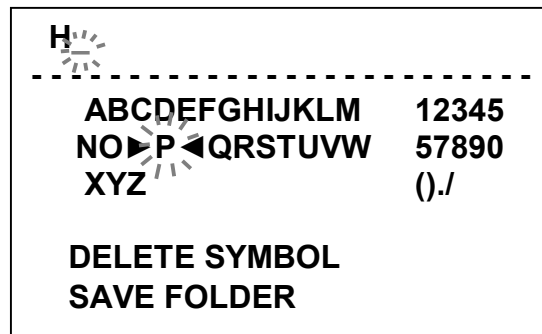






Fig. 1.28


To delete a character, move the cursor to DELETE SYMBOL and depress the  key. The last entered character shall be deleted.


If sixteen characters were entered, the alphabet shall disappear, and the cursor shall automatically move to DELETE SYMBOL command.

Using the key  to delete as many characters as needed.

Depress the key , the alphabet shall appear again and the folder name may be entered on.

To save the folder made, move the cursor to SAVE FOLDER command and depress the key . The analyzer shall go over to the **SCRATCHPAD EDITOR** display.

If the pad contains a folder bearing the name which is entered, on pressing the key , the "FOLDER WITH SUCH NAME ALREADY EXISTS" message shall appear on the screen. The cursor may be moved against DELETE SYMBOL command to change the folder name.

If the key  is depressed the "CREATED FOLDER IS NOT SAVED" message shall appear for 2 s. The analyzer shall go over to the SCRATCHPAD EDITOR display.

#### 4 DELETE FOLDER display is shown in Fig. 1.29.

The folders are saved in the order they have been made.

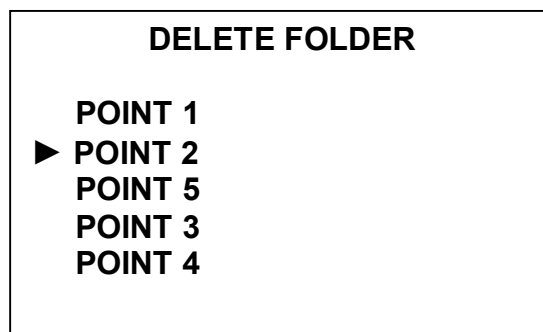



Fig. 1.29

To delete a folder, paste the folder using the cursor. Press the key . The display shall show the name and content of the folder as shown, for instance, in Fig. 1.30.

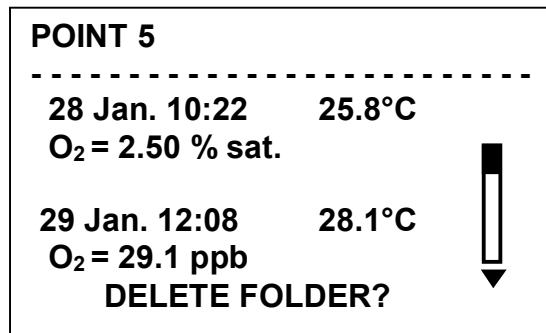



Fig. 1.30

If a folder contains no records, the display shall show NO RECORDS message.



Press the key . The FOLDER DELETED message shall appear on the screen for 2 s, and the analyzer shall go over to DELETE FOLDER display.


Other folders except SHARED FOLDER may be deleted in the same manner.

#### 1.5.8.5 ► SALINITY menu command

► **SALINITY** is the menu command used to enter salt content values in measurements in salt water.

On selection of this command the display with an intermittent figure shown in Fig. 1.31 shall come up.

Using the keys  and  set up the desirable salt content. The figure may vary from 0 to 99 ppt.

Press the key  and "SAVED!" message shall appear at the screen bottom for 2 s and the analyzer shall go over to the **MENU** display.

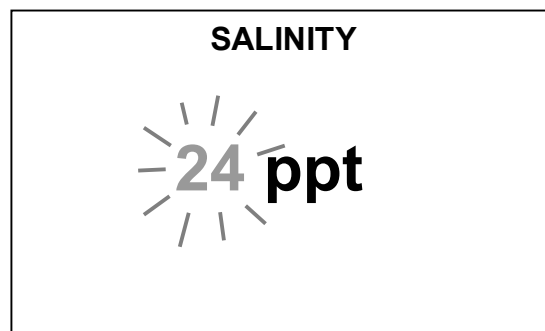


Fig. 1.31



### 1.5.9 Warning displays

On appearing displays shown in Fig. 1.32-1.35, refer to 2.6 of the Operation Manual (Troubleshooting. Table 2.1).

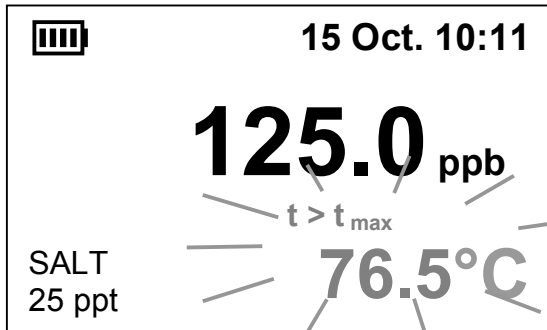


Fig. 1.32

The display shown in Fig. 1.32 comes up when analyzable fluid temperature exceeds 50.0 °C. Simultaneously an audible signal comes on.

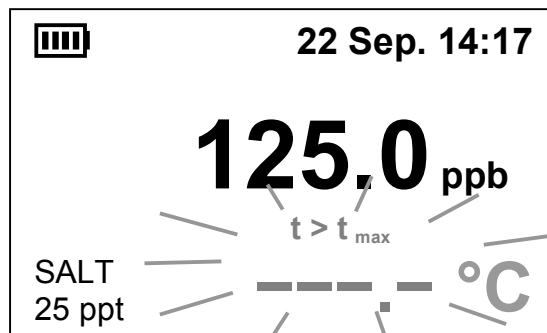


Fig. 1.33

The display shown in Fig. 1.33 comes up when temperature exceeds 99.9 °C (failure in the temperature measuring channel).



Fig. 1.34

The display shown in Fig. 1.34 comes up when analyzable fluid temperature is below 0 °C.

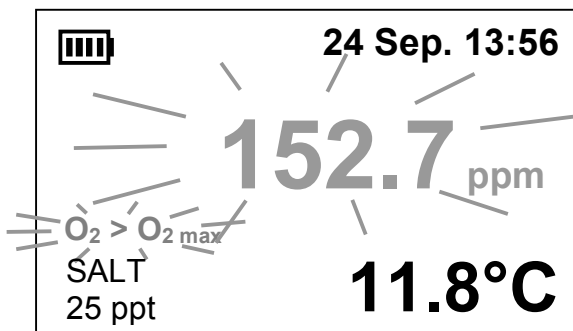
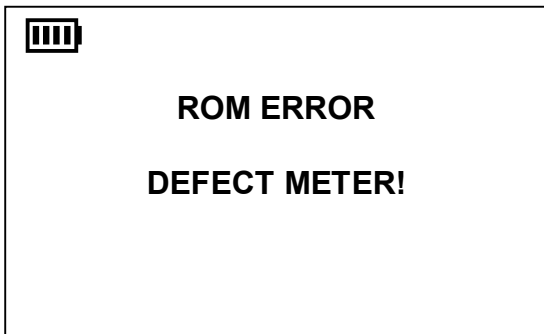


Fig. 1.35

The display shown in Fig. 1.35 comes up on measuring DOC values over 150 ppm.

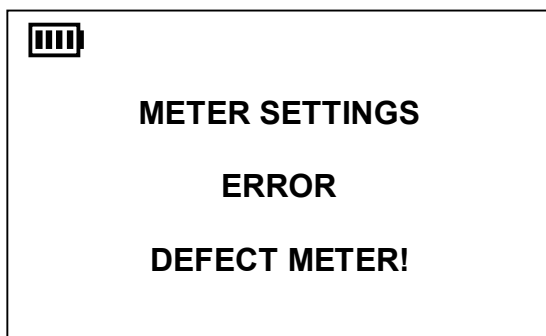
If a value exceeds 199.9 ppm, instead, dashes shall come up.

### 1.5.10 Error displays



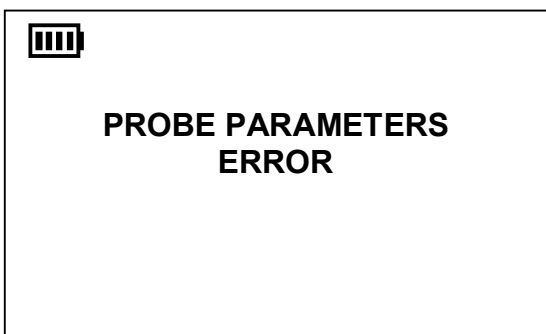
*Fig. 1.36*

The display shown in Fig. 1.36 comes up in the event of analyzer program failure. Refer to 2.6 of the Operation Manual (Troubleshooting. Table 2.1).



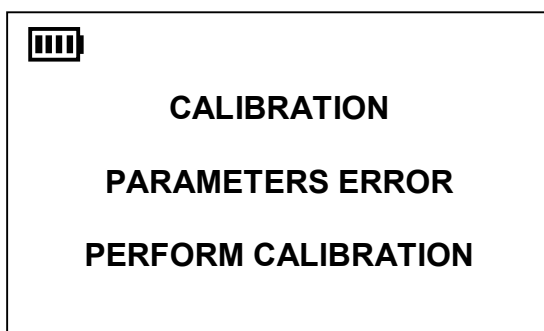
*Fig. 1.37*

The display shown in Fig. 1.37 comes up in the event of analyzer program failure. Refer to 2.6 of the Operation Manual (Troubleshooting. Table 2.1).



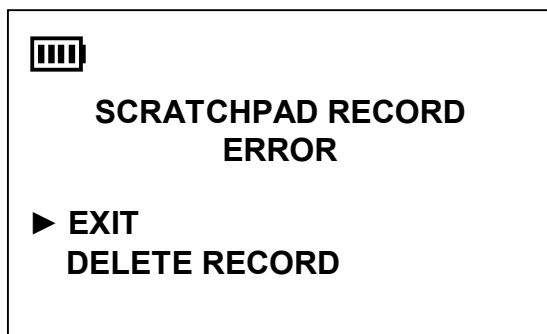
*Fig. 1.38*

The display shown in Fig. 1.38 comes up in the event of analyzer program failure.



*Fig. 1.39*

The display shown in Fig. 1.39 comes up in the event of program failure in analyzer calibration. Carry out calibration.



*Fig. 1.40*

The display shown in Fig. 1.40 comes up in the event of erroneous record in the pad.

On selection of **DELETE RECORD** command the record shall be deleted with no warning and the meter shall return to the measurement mode.

On selection of **EXIT** command the meter shall return to the measurement mode.

On viewing this record in the pad the display shall show **ERROR** message.

### ***1.6 Measuring instruments, tools and appliances***

The analyzer maintenance shall additionally require the following tools and appliances not included into the delivery set:

- 2 mm cross screwdriver;
- B-1-250 beaker;
- KH-100-19/26 flask;
- chemically pure hydroquinone;
- chemically pure sodium or potassium hydroxide.

It is possible to use:

- chemically pure sodium sulphite  $\text{Na}_2\text{SO}_3$ ;
- chemically pure potassium permanganate  $\text{KMnO}_4$ .

## **2 INTENDED USE**

### ***2.1 Operating limitations***

2.1.1 The MAPK-303E analyzer is mostly used to measure DOC in surface and waste water, including turbid and hued, containing organic contaminant.

2.1.2 Permissible concentrations of a number of ingredients that affect the measurement results are set out in 1.2.5.

2.1.3 When using the analyzer, protect the oxygen probe against any shock since its design uses glass.

### ***2.2 Safety Precautions***

2.2.1 The dissolved oxygen analyzer is to be operated by people who acquainted themselves with this manual and safety rules for handling reagents and solutions according to GOST 12.1.007-76 and GOST 12.4.021-75.

2.2.2 The analyzer meets safety requirements of Class III according to GOST R 52319-2005. Rated supply voltage varies from 2.2 to 3.4 V. Grounding is not required.

2.2.3 The analyzer electromagnetic compatibility meets requirements of GOST R 51522-99 for class B equipment.

### ***2.3 Analyzer pre-starting procedures***

Before use, unpack analyzer, check components and make sure that the products are free of damage.

If the analyzer was held in cold environment, keep it at room temperature for at least 1 h and then start preliminary operating procedures.

### 2.3.1 Connection of power supply

To connect power supply, remove the dry cell compartment cover on the rear panel of the convertor unit. Install two AA alkaline dry cells or two charged AA nickel-metal hydride batteries according to marking in the compartment. Close the dry cell compartment cover.


When the meter is turned on the display shall show the cell charge level. The number of bars in the cell symbol shows the dry cell charge level as follows: one bar – 25 %, two bars – 50 %, three bars – 75 %, four bars – 100 %.

**1 WARNING: OBSERVE POLARITY when connecting power supply. Otherwise this may cause analyzer failure!**

**2 WARNING: Connect power supply only when the analyzer is de-energized!**

**3 WARNING: To prevent date and time resetting and loss of data in the scratchpad, batteries or dry cell are to be replaced within a 30-second period!**

Nickel-metal hydride batteries shall be charged with 5V voltage and analyzer connected to the PC USB port.

The dry cell compartment is provided with the  sign ("**WARNING!**") warning that the analyzer may not be connected to USB port if the meter uses AA alkaline dry cells. To connect the meter to the USB port, remove them from the compartment and replace with two AA nickel-metal hydride batteries.

### 2.3.2 To make oxygen probe available

The oxygen sensor is supplied in the analyzer complete set in "dry" condition and is to be filled with electrolyte from the complete set as prescribed in 2.6.3 and submerged in distilled water for at least 8 h.

In this case two AA alkaline dry cells or two AA nickel-metal hydride batteries are to be installed in the convertor unit. Whether the analyzer is ON or OFF, polarization voltage shall be applied to the sensor to shape the electrode system.

### 2.3.3 Check for analyzer's workability

Check for analyzer's workability includes:

- preliminary analyzer calibration against oxygen in the atmospheric air; and
- check for readings in the "zero" solution.

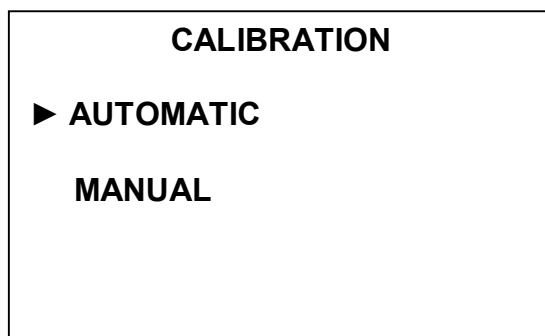
Check for analyzer's workability is to be carried out:

- after filling the probe with electrolyte on receiving the analyzer;
- after replacement of the membrane assembly or Teflon film;
- if analyzer operation raises doubts.


### 2.3.3.1 Preliminary analyzer calibration

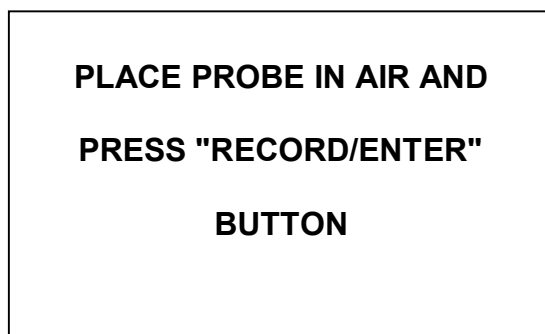
Turn on the analyzer.

- 1 Press the key . The display shown in Fig. 2.1 shall come up.




*Fig. 2.1*

- 2 Move the marker to **AUTOMATIC** command and depress the key . The display shown in Fig. 2.2 shall come up.



*Fig 2.2*

- 3 Remove the probe from the vessel with water and place horizontally in air (for instance, place on a table), hold for 5 min and press the key . The display shown in Fig. 2.3 shall come up, first, and then the display shown in Fig. 2.4.

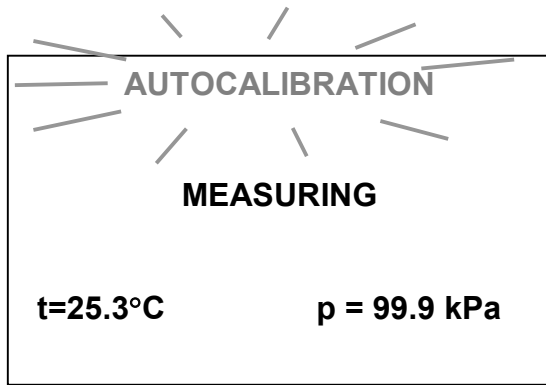


Fig. 2.3

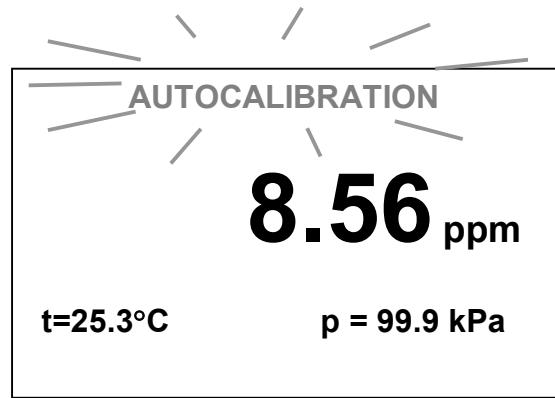


Fig. 2.4

- 4 Press the key . The display shown in Fig. 2.5 shall come up.

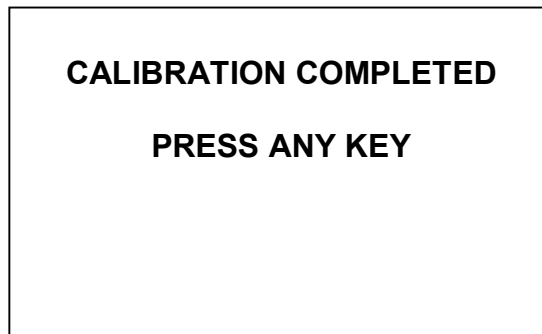


Fig. 2.5

If displays shown in Fig. 2.6 and Fig. 2.7 have come up, refer to 2.6 "Troubleshooting".

- 5 Press any key and the analyzer shall go over to the measurement mode.

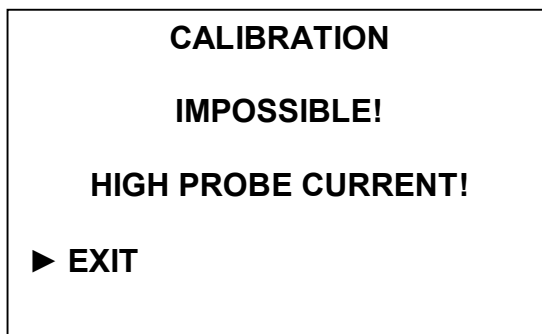


Fig. 2.6

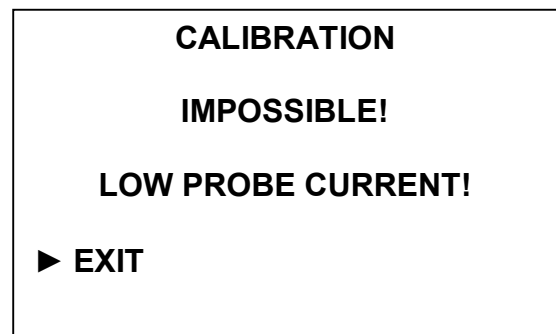


Fig. 2.7

### 2.3.3.2 Check for readings in the "zero" solution

Prepare oxygen-free ("zero") solution. To do so:

- prepare alkali solution (KOH or NaOH) of 5 ppt concentration;
- transfer the solution to a 0.3-0.5 dm<sup>3</sup> vessel to 50-60 mm capacity; and
- add 0.3-0.5 g of hydroquinone and mix.

The prepared solution stored in a tightly closed container shall be suitable for a 1-month period.

Submerge the probe into the solution with the membrane downward and using it, gently shake the solution to prevent air bubbles accumulation on the membrane. Analyzer display readings are to drop slowly.

Take analyzer readings in 30 min. They should be in the range of  $\pm 50$  ppb.

Successful completion of the above procedure shall mean that the analyzer is available for normal operation. Then the analyzer calibration against atmospheric air is to be carried out in accordance with 2.3.4.

If readings do not drop down to the abovementioned values, the probe "cycling" should be undertaken in compliance with 2.3.3.3.

**Note** – Another oxygen-free ("zero") solution may be prepared. To do so:

- prepare sodium sulphite solution Na<sub>2</sub>SO<sub>3</sub>, chemically clean, of 10 ppt;
- transfer the solution to a 0.3-0.5 dm<sup>3</sup> capacity vessel to the level not less than 50 mm;
- prepare potassium permanganate solution KMnO<sub>4</sub> of 5 ppt; and
- add 2-3 cm<sup>3</sup> KMnO<sub>4</sub> solution in the vessel with Na<sub>2</sub>SO<sub>3</sub> solution and stir.

The prepared solution shall be suitable for 2-3-hours period.

### 2.3.3.3 Probe cycling

For cycling proceed as follows:

- switch on the analyzer;
- prepare "zero" solution according to 2.3.3.2;
- submerge the probe into the "zero" solution with the membrane downward and using it, gently shake the solution to prevent air bubbles accumulation on the membrane;
- hold the probe in the "zero" solution for 5 min and then remove it to ambient air for 5 min and shake drops of the solution off the membrane;
- repeat the "zero" solution – air cycle 3-4 times;
- submerge the probe into the "zero" solution again;
- take analyzer readings in a 10-minute period. They should lie within  $\pm 50$  ppb.



Then carry out calibration according to 2.3.4 or 2.3.5.

If the analyzer readings in the "zero" solution during above operations do not drop down to said values, this may be indicative of low quality of the "zero" solution (low quality of reagents and solutions), or analyzer failure (2.6 "Troubleshooting").

### 2.3.4 Analyzer atmospheric air calibration ("automatic")

Automatic analyzer calibration is undertaken:

- when the meter is new;
- on a shift basis (8 h); and
- after replacement of electrolyte, membrane or Teflon film.

The analyzer may be calibrated in atmospheric air of temperature from plus 15 to plus 35 °C at 100 % relative humidity. Preferably, calibration is to be undertaken at room temperature.

Prior to calibration the meter is to be held at room temperature for at least 1 h with AA alkaline dry cells or AA metal hydride batteries.

Prior to calibration the probe is to be fully submerged in distilled water for at least 10 min at room temperature.

Switch on the analyzer.

- 1 Press the key . The display shown in Fig. 2.8 shall come up.

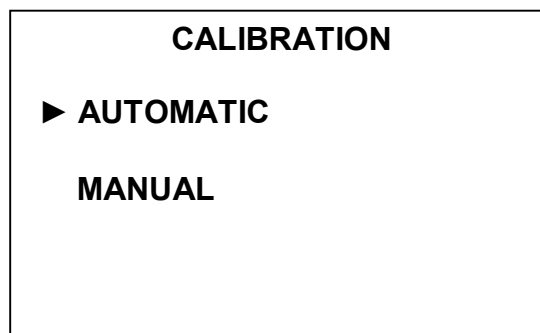



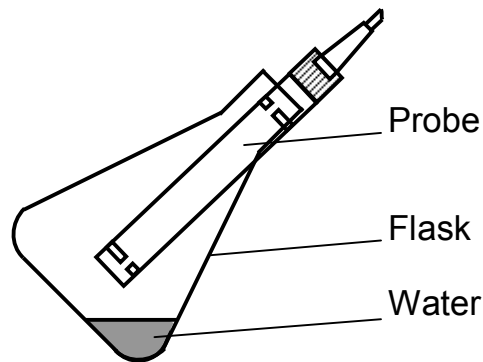
Fig. 2.8

- 2 Move the marker to **AUTOMATIC** command and depress the key . The display shown in Fig. 2.9 shall come up.


**PLACE PROBE IN AIR AND  
PRESS "RECORD/ENTER"  
BUTTON**

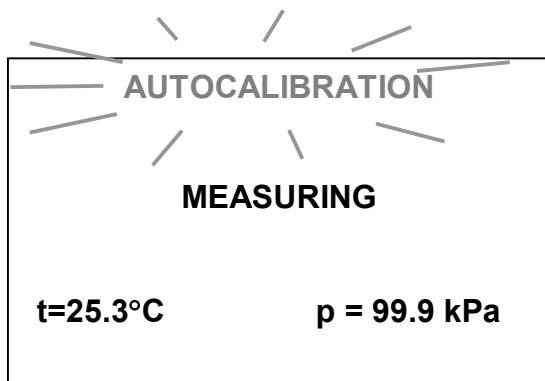
*Fig. 2.9*

- 3 Shake water drops off the probe membrane and place the probe into a KH-100-19/26 conical flask or a similar vessel filled with water of 3-5 mm layer as shown in Fig 2.10. The flask is to be inclined at 30-45° angle to the horizontal so that residual water might flow down the membrane.

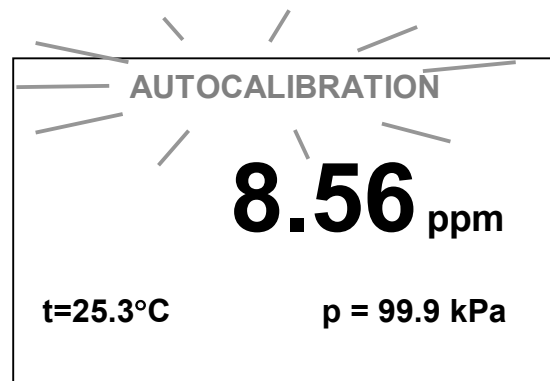


*Fig. 2.10 – Probe position in a flask on analyzer calibration*


- 4 Press the key . The display shown in Fig. 2.11 shall come up, first, and then the display shown in Fig. 2.12. The display shall show the measured DOC value with regard to calibration coefficients of the previous calibration.

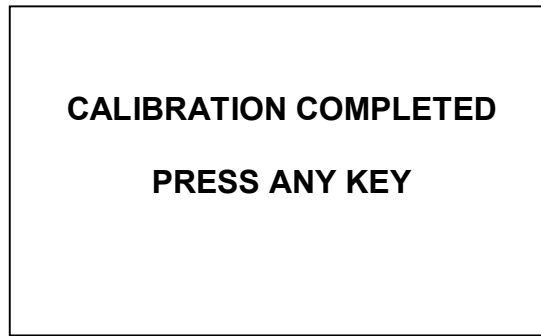


*Fig. 2.11*




*Fig. 2.12*

- 5 As soon as analyzer readings become steady (approximately in 10 min) press the key . The display shown in Fig. 2.13 shall come up.




*Fig. 2.13*

If in 10 min the key  is not depressed, the analyzer shall terminate calibration process and go over to the display shown in Fig. 2.13.

**6** Press any key and the analyzer shall go over to the measurement mode. If displays shown in Fig. 2.6 and Fig. 2.7 have come up, refer to 2.6 "Troubleshooting".

After calibration the analyzer is available for operation.

**Note** – Analyzer calibration against atmospheric air may be cancelled prior to operation 5 depressing the key . The analyzer shall go over to the measurement mode and save calibration coefficient values of the previous calibration.

### **2.3.5 Analyzer calibration against GSO CGM with known oxygen content in % vol. or against a solution with known DOC value ("manual")**

This calibration is undertaken additionally to reduce inaccuracy of measurements. Analyzer GSO CGM calibration is to be carried out either against a solution with known DOC value or oxygen content close to the values measured.

Prior to manual calibration, an automatic calibration against atmospheric air is recommended.

#### **2.3.5.1.1 Analyzer calibration against CGM**

Prior to calibration the meter is to be held at room temperature for at least 1 h with AA alkaline dry cells or AA metal hydride batteries.

For calibration assemble the package in compliance with Fig. 2.14.

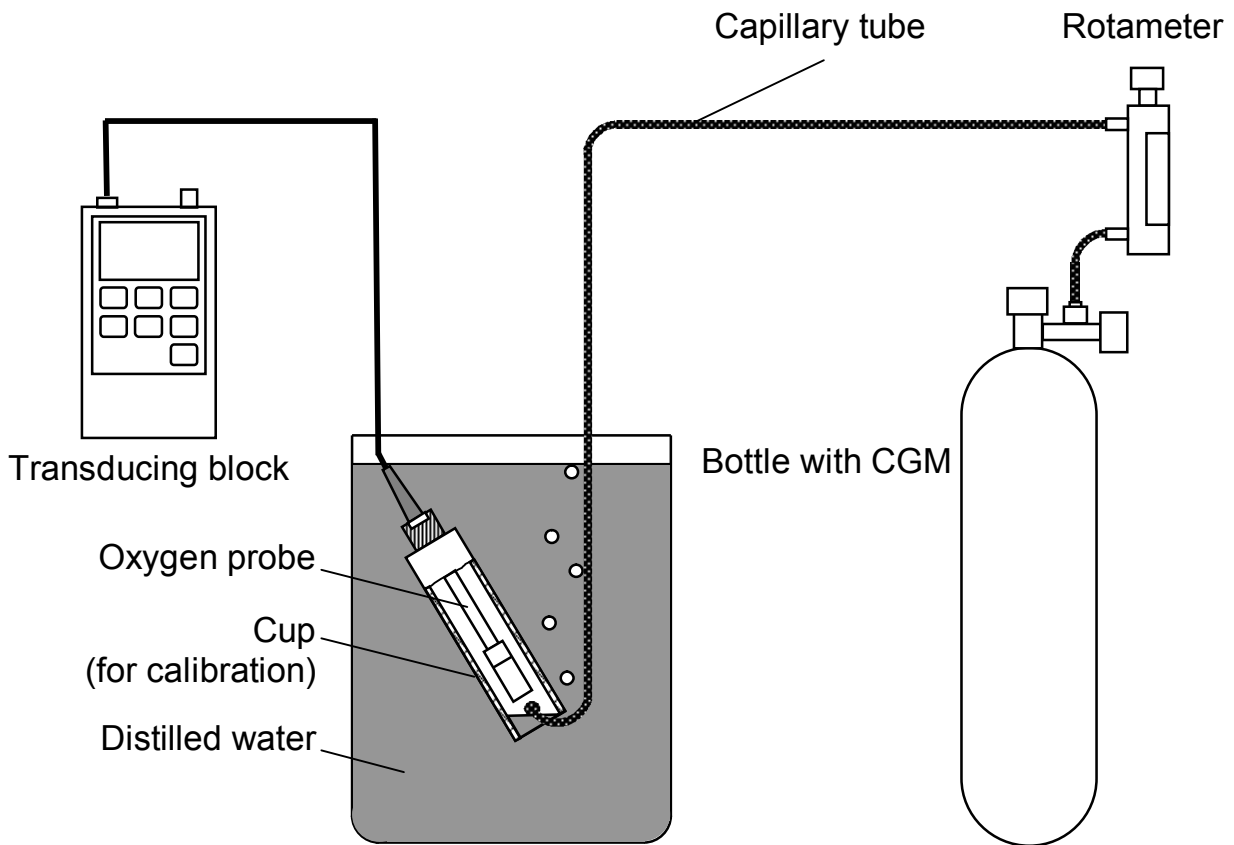



Fig. 2.14

- 1 Press the key . The display shown in Fig. 2.15 shall come up.

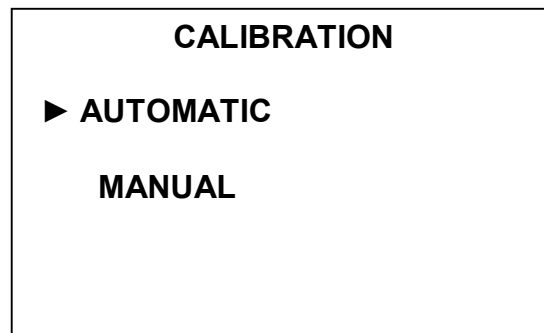



Fig. 2.15

- 2 Move the marker to **MANUAL** command and depress the key . The display shown in Fig. 2.16 shall come up.

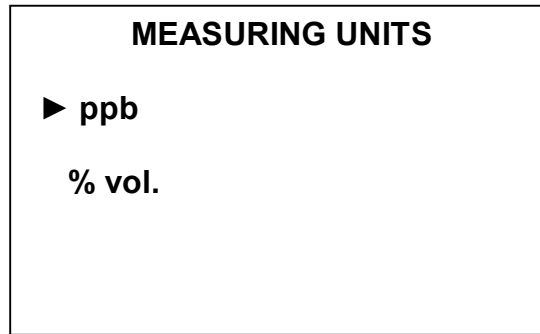



Fig. 2.16

- 3 Move the marker to the "% vol." command and press the key . The display shown in Fig. 2.17 shall come up, first, and then the display shown in Fig. 2.18.

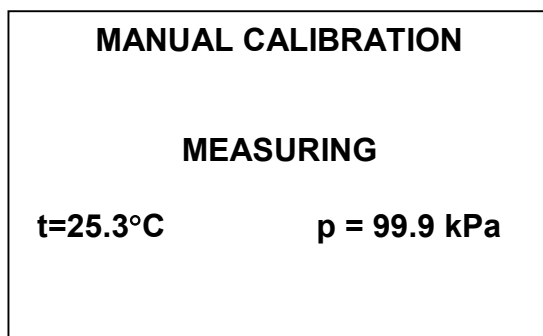


Fig. 2.17

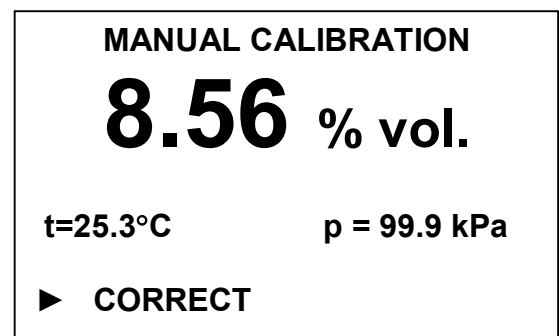



Fig. 2.18

- 4 Press the key . The display shown in Fig. 2.19 shall come up.

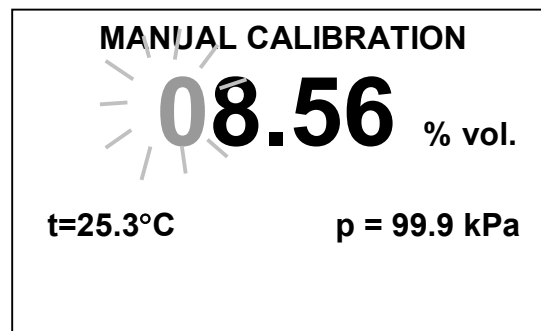





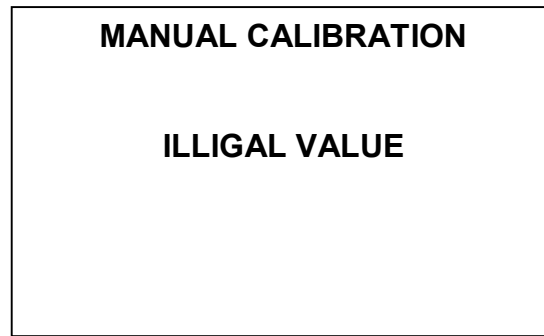


Fig. 2.19

- 5 To move within the command to the left and to the right, use the keys  and . The digit that may be changed using the keys  and  starts flickering. Once the desired value has been set up (oxygen volume concentration in % vol. taken from the certificate of the used CGM) press the key , and the analyzer shall go over to the measurement mode.

If a value below 0.05 % vol. or above 21 % vol. is entered, the display shown in Fig. 2.20 shall appear for 2 s, and then the analyzer shall go over to the display


shown in Fig. 2.19 with entered value of oxygen volume concentration in the CGM in % vol.



*Fig. 2.20*

If displays shown in Fig. 2.6 and Fig. 2.7 have come up, refer to 2.6 "Troubleshooting".


### **Notes**

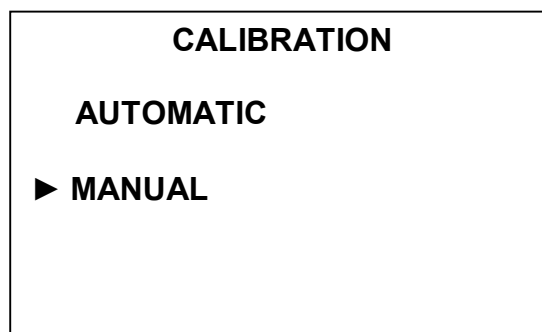
**1** Analyzer calibration against CGM may be cancelled prior to operation 4, depressing the key . The analyzer shall go over to the display shown in Fig. 2.15 and save calibration coefficient values of the previous calibration.

**2** If a salt content value was entered prior to change to the manual calibration mode, the analyzer shall be calibrated with regard to salt content.


### 2.3.5.2 Analyzer calibration against solution with known DOC value

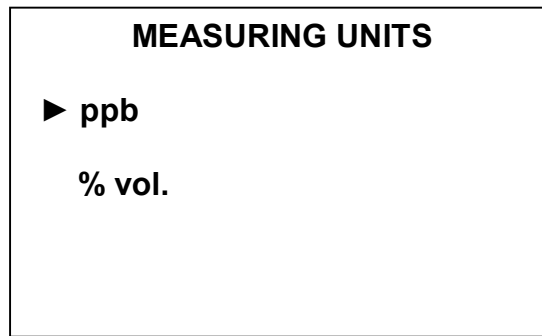
Calibration against solution with known DOC value is to be undertaken if, for instance, a reference dissolved oxygen analyzer is available. In this case DOC in the same solution is to be measured by the reference and working analyzers. Wait for stable readings of both analyzers.

Press the key . The display shown in Fig. 2.21 shall come up.




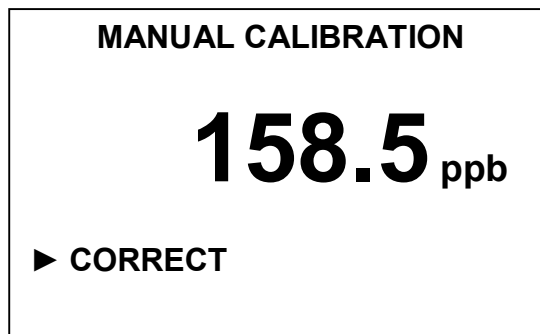
*Fig. 2.21*

- 1 Move the marker to **MANUAL** command and depress the key . The display shown in Fig. 2.22 shall come up.




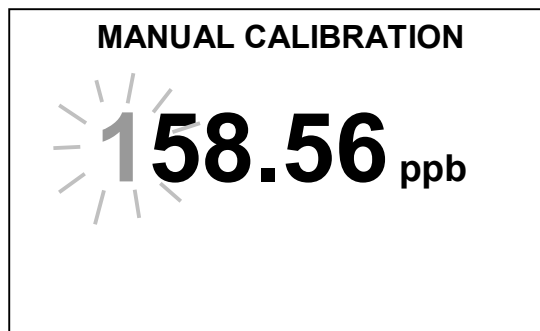
*Fig. 2.22*

- 2 Move the marker to the "**ppb**" command and press the key . The display shown in Fig. 2.23 shall come up indicating value in ppb.








*Fig. 2.23*

- 3 Press the key . The display shown in Fig. 2.24 shall come up.




*Fig. 2.24*

- 4 To move within the command to the left and to the right, use the keys  and . The digit that may be changed using the keys  and  starts flickering. Once the desired value has been set up, press the key  and the analyzer shall go over to the measurement mode.

If a value below 50.0 ppb or above 2000.0 ppm is entered, the display shown in Fig. 2.20 shall appear for 2 s, and then the analyzer shall go over to the display shown in Fig. 2.24 with entered DOC value.

If displays shown in Fig. 2.6 and Fig. 2.7 have come up, refer to 2.6 "Troubleshooting".

### **Notes**


**1** Analyzer calibration against CGM may be cancelled prior to operation 4, depressing the key . The analyzer shall go over to the display shown in Fig. 2.15 and save calibration coefficient values of the previous calibration.

**2** If a salt content value was entered prior to change to the manual calibration mode, the analyzer shall be calibrated with regard to salt content.

## **2.4 Measurement procedure**

### **2.4.1 Measurements in reservoir**

The probe for MAPK-303E is supplied with protective cap with carving, screwed on protective bushing. It protects electrode part of the probe from drying up during transportation.

Before measuring in reservoir it is important to put protective cap off and submerge the probe in the analyte reservoir as deep, as important. Permit water flow, moving the probe up and down with azimuth angle of 10-15 cm once in 2-5 s (if there is a water flow in the reservoir, the probe may be motionless). After measurements are determined, fix the values in mg/dm<sup>3</sup> of % saturation, choosing indication mode with  button.

### **2.4.2 Measurement of oxygen at depth up to 20 m**

Oxygen probe permits to measure dissolved oxygen at depth up to 20 m if ordered cable extension. Due to rubber bushing, on which the membrane is fitted, equalizes hydrostatic pressure of membrane assembly's intracavity and ambient medium. In addition the measurements stay constant if oxygen concentration is constant, independent of hydrostatic pressure.

**WARNING: Before measuring deeply check, that membrane assembly is fully filled with electrolyte!**



### 2.4.3 Measuring in standard BOD flask

While measuring in standard oxygen BOD flask in accordance with Fig. 2.25 it is needed:

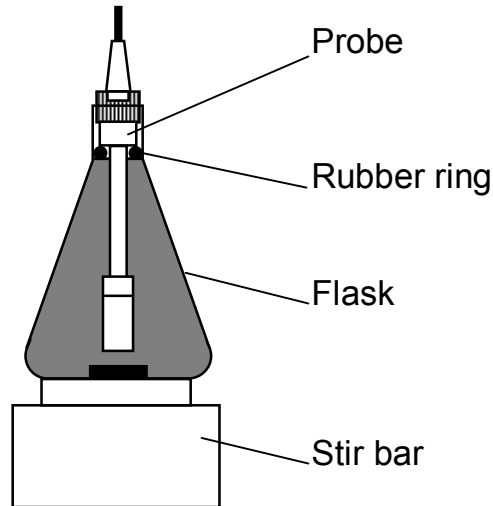



Fig. 2.25

- submerge the cane of stir bar in flask;
- screw off protective bushing and take it off. Put the probe in the flask, firming it in the flask neck with rubber ring, installed on the measuring part of the probe;
- put the flask on the stir bar and turn it on.

**Note** – The rubber ring is not included in the meter kit and should be selected in accordance with flask's size.

Turn the meter on. With button  choose indication of DOC in ppm or % sat.

The speed of water flow of analyte water along the membrane should be min 5 cm/s. In stationary fluid the measurements would lower slowly.

The DOC  $t_y$  measuring process before getting the fixed value is max 2 min.

#### **Note**

1 If the temperature of the probe and aquatic environment differs, the readout setting time is 3-5 min.

2 If there is no stir bar, it is recommended to submerge in the flask glass or plastic balls and stir arm circling the flask till the readout set (about 2 min).

3 If values of dissolved oxygen decrease slowly and do not set in admitted time, then there may be air bubbles on the membrane. If so, it is important:

- while measuring in reservoir, stir the probe harshly leaving it submerged in the water;
- while measuring in BOD flask, invert the flask with the probe in it and stir. In viscous medium it is necessary to clean the membrane from time to time (para.2.6.2).

**WARNING! While working with analyzer:**

- do not let the membrane dry up. Between the measurements the membrane should be submerged in distilled or boiled water;
- put protective cap on, when transporting oxygen probe DOP-303E. Foam is set in the cap. Before transporting, one should moist the foam. To do so, fill the cap with the water and pour it out;
- when moving the device from cold environment to the warm one, before switching it on, leave it for at least 1 h in the room.

## **2.5 Inspection of condition**

The analyzer shall be recognized to be in normal working condition if it meets the following requirements:

- analyzer readings do not exceed  $\pm 50$  ppb when the probe is placed in the "zero" solution;
- on calibration against atmospheric air (2.3.4) the displays shown in Fig. 2.6 and 2.7 do not come up and on calibration the readings  $C_{cal}$ , ppm are settled with accuracy of  $\pm 1$  % of the value predetermined from the formula

$$C_{cal} = Co_2(t) \cdot \frac{P_{atm}}{101,325},$$

where  $Co_2(t)$ , ppm is solubility of oxygen contained in air of 100 % humidity in distilled water at temperature  $t$ , °C, normal atmospheric pressure of 101.325 kPa according to table B.1;

$P_{atm}$  is atmospheric pressure during calibration, kPa.

## **2.6 Troubleshooting**

2.6.1 Typical analyzer troubles and remedies are tabulated in Table 2.1.

In the event of troubles shown in Table 2.1 it is necessary to take corrective actions recommended in the "Remedy" column in compliance with paragraphs below and Figures 1.1, 2.28.

Table 2.1

Trouble	Probable cause	Remedy
1 With power ON display shows no indications and readings	Poor contact in the dry cell compartment	Open the dry cell compartment and clean contacts of dry cells or batteries
	Supply voltage is below the allowable value	2.3.1. Replace dry cells or charge batteries
2 With power ON display shows all or random segments and signs	Discharged dry cells or batteries	2.3.1. Replace dry cells or charge batteries
3 On checking "zero" point analyzer readings go beyond $\pm 50$ ppb	Torn or pierced membrane, affected sensor tightness	2.6.6, 2.6.4. Replace membrane and electrolyte
	Moisture ingress into the convertor unit	Dry up the convertor unit for 3-4 days
	Stretched membrane	2.6.4. Replace membrane assembly
	Low-quality "zero" solution	Replace "zero" solution
	Broken (cracked) probe electrode glass tube-holder	To be repaired at factory
4 On analyzer calibration against atmospheric air the display with "CALIBRATION IMPOSSIBLE. LOW PROBE CURRENT" message comes up	No electrolyte	2.6.3. Fill electrolyte
	Dirty membrane	2.6.2. Clean membrane
	Dry membrane	Make membrane wet for 2-3 days without probe disassembly
	Defective membrane	2.6.4. Replace membrane assembly
	Analyzer probe is in a medium other than atmospheric air	Place the probe in air
5 Too slow response to change in oxygen concentration	Dirty membrane	2.6.2. Clean membrane
	Dirty platinum electrode	2.6.5. Clean platinum electrode
6 Electrolyte leaks rapidly	Torn membrane	2.6.4. Replace membrane assembly

Table 2.1 continue

Trouble	Probable cause	Remedy
7 Display with "ROM ERROR, DEFECT METER" message comes up. The analyzer responds to only power key manipulation.	Unrepairable error	To be repaired at factory
8.1 Analyzer readings change rapidly and are unstable. 8.2 On analyzer calibration against atmospheric air the display with "CALIBRATION IMPOSSIBLE. HIGH PROBE CURRENT" message comes up	Torn membrane	2.6.4. Replace membrane assembly
	Dirty electrolyte	2.6.3. Replace electrolyte
	Moisture ingress into the measuring block	Dry up the convertor unit for 3-4 days
	Torn Teflon film	2.6.4. Replace Teflon film
	Analyzer probe is in a medium other than atmospheric air	Place the probe in air
9 The display with "METER SETTINGS ERROR, DEFECT METER" message comes up. The analyzer responds to only power key manipulation.	Unrepairable error	To be repaired at factory
10 The display with "PROBE PARAMETERS ERROR" message comes up	Temperature measuring channel failure (broken temperature sensor)	To be repaired at factory
11 The display with "CALIBRATION PARAMETERS ERROR, PERFORM CALIBRATION" message comes up (Fig. 1.39)	Analyzer program failure	Carry out calibration
12 During measurements the display shows "O <sub>2</sub> >O <sub>2</sub> max" message (Fig. 1.35) which flickers with the value. It means that the measured DOC value exceeds permissible limit for indication.	Torn membrane	2.6.4. Replace membrane assembly
	Dirty electrolyte	2.6.3. Replace electrolyte
	Moisture ingress into the measuring block	Dry up the convertor unit for 3-4 days
	Torn Teflon film	2.6.4. Replace Teflon film
	Analyzer failure	To be repaired at factory

## 2.6.2 Membrane cleaning

To clean the probe membrane, use a piece of cotton wool wet with alcohol. The probe membrane may be submerged in a weak solution (2 %) of sulfuric acid for about 1 h and then flushed under running water.

## 2.6.3 Filling (refilling) the probe with electrolyte

Filling the probe with electrolyte is required on receiving the meter from the manufacturer since it is supplied dry (without electrolyte).

Loosen and remove the protective sleeve from the probe according to Fig. 2.26.

Remove the membrane assembly from the sleeve. Draw electrolyte from the spare parts kit into a syringe. Carefully hold the membrane assembly vertically with membrane downward so as not to damage the membrane and inject electrolyte to 2/3 capacity. Holding the membrane assembly filled with electrolyte vertically, put it onto the sleeve as far as it will go. Screw on the protective sleeve.

**WARNING: The membrane is to be tightened and closely keep to the platinum electrode of the probe. PREVENT separation of the membrane from the cathode!**

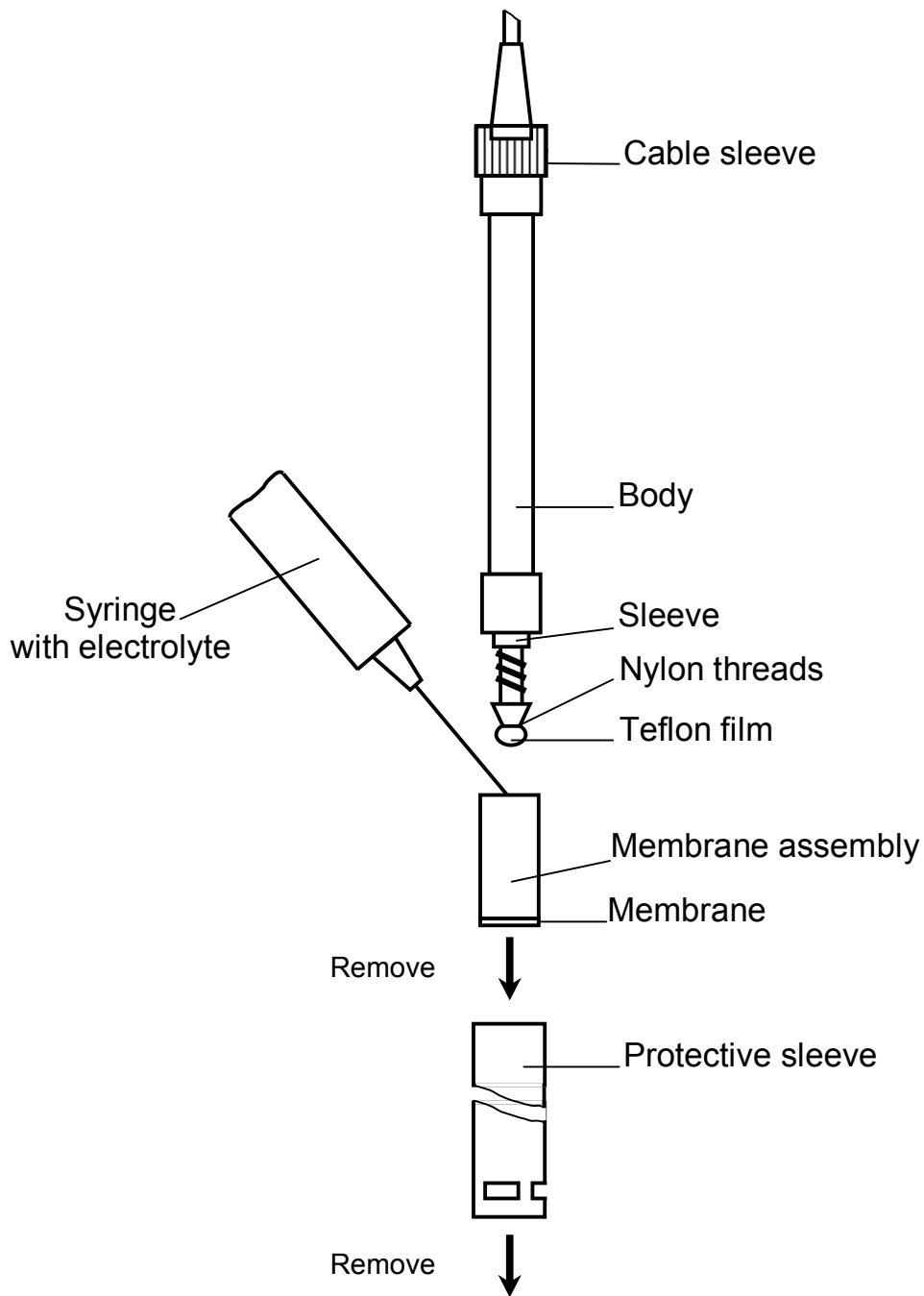
In operation, volume of electrolyte may decrease due to outflow through micro orifices in the membrane. In this case the residual electrolyte in the probe is to be replaced.

When replacing electrolyte, remove the membrane assembly from the sleeve 6 and drain electrolyte from the assembly. Wash the membrane assembly with distilled water and fill fresh electrolyte.

Electrolyte ingredients: chemically pure KCl – 14 g; chemically pure KOH – 0.2 g; trilon B – 0.15 g; distilled water to 0.1 dm<sup>3</sup>. Solution is to be filtered.

## 2.6.4 Replacement of the membrane assembly and Teflon film

2.6.4.1 The membrane assembly may require replacement in the event of mechanical membrane damages (cracks, tears) or stretching. Symptoms of the defects include instability of analyzer readings, high analyzer readings in the "zero" solution, and slow response on DOC measurements.



*Fig. 2.256 – Pattern of probe disassembly for electrolyte filling and replacement, replacement of Teflon film and membrane assembly*

Loosen and remove the protective sleeve from the probe according to Fig. 2.28. Remove the membrane assembly from the casing and drain electrolyte from the assembly.

Check for the Teflon film integrity.

The film should closely keep to the cathode and have no creases. If the film has mechanical damages, it is subject to replacement.

On removing the Teflon film, inspect the probe electrodes:

- platinum cathode 1 (Fig. 1.1b) embedded into a glass tube should be clean;
- silver anode 2 coiled round the tube is to be of grey color.

If required, electrodes shall be cleaned using a piece of cotton wool wet with alcohol.

**WARNING: DO NOT USE abrasive materials for cleaning electrodes!**

2.6.4.2 In the event of the Teflon film damage replace it by a new film from the spare parts kit. To do so, apply it onto the cathode surface and press film edges to the glass tube surface. Holding them by hand wind up and 5-6 coils of nylon thread and make 2-3 knots. Cut off excessive Teflon film 3-5 mm from the nylon threads using scissors.

**WARNING: Teflon film MUST BE FREE of tears and holes near the platinum electrode!**

Take new membrane assembly from the SPTA kit. Hold it vertically, fill it with electrolyte and carefully put it onto the sleeve. Mount and tighten the protective sleeve.

After replacement of the membrane assembly or Teflon film carry out operations in 2.3.3, 2.3.4.

### 2.6.5 Cleaning of platinum electrode

The platinum electrode is to be cleaned in a special solution 6-12 months after commissioning. Earlier cleaning is not required.

To clean the electrode, prepare two solutions.

Ingredients of the solutions:

- solution No 1: hydrochloric acid (concentrated) – 50 cm<sup>3</sup>, distilled water – to 100 cm<sup>3</sup>;
- solution No 2: acetic acid (80-100 %).

Fill solutions to vessels to the height of 3 mm. Then proceed as follows:

- remove Teflon film;
- place probe into the vessel with the first solution and hold for 1 h;
- wash the probe with distilled water;
- place probe into the vessel with the first solution and hold for 1 h;

**WARNING: DO NOT drop silver anode into the solutions!**

- wash the probe with distilled water.

Then proceed to 2.6.4.2.

### **2.6.6 Setting of initial analyzer parameters**

A provision is made in the meter for setting the analyzer initial parameters including shift (zero shift) and slope which corresponds to an "average" probe. This makes it possible to start calibration with preset initial conditions.

The mode is to be used if analyzer calibration performance is doubtful.

Initial parameters are to be set up according to 1.5.8.



### 3 MAINTENANCE

Analyzer maintenance comprises:

- analyzer calibration against atmospheric air (2.3.4) to be carried out at least once every 10 days;
  - probe cycling (2.3.3) to be carried out if the analyzer downtime exceeds 24 h. This operation ensures the meter quickest response in DOC measurements.
- If conditions in 2.5 are met, the analyzer ensures performance laid down in 1.3.

### 4 DELIVERY SET

4.1 Analyzer delivery set is shown in Table 4.1.

*Table 4.1*

Description	Identification	Quantity
1 MAPK-303E dissolved oxygen analyzer	BP47.00.000-1	1
2 Spare parts (for oxygen probe)	BP47.08.000	1
3 Tools and accessories kit	BP47.04.000	1
4 Tools and accessories kit	BP47.09.000	1*
5 Operation Manual	BP47.00.000-01PЭ	1

\*The tools and accessories kit content is to be agreed with the customer.

**ATTACHMENT A**  
**Solubility of 100%-humidity air oxygen in distilled water depending on**  
**temperature**  
*(reference)*

$P_{atm} = 101.325 \text{ kPa}$

**Table A.1**

in ppm

t °C	0	0.1	0.2	0.3	0.4	0.5	0.6	0.7	0.8	0.9
0	14.62	14.58	14.54	14.50	14.46	14.42	14.38	14.34	14.30	14.26
1	14.22	14.18	14.14	14.10	14.06	14.02	13.98	13.94	13.90	13.87
2	13.83	13.79	13.75	13.72	13.68	13.64	13.60	13.57	13.53	13.49
3	13.46	13.42	13.39	13.35	13.32	13.28	13.24	13.21	13.17	13.14
4	13.11	13.07	13.04	13.00	12.97	12.93	12.90	12.87	12.83	12.80
5	12.77	12.74	12.70	12.67	12.64	12.61	12.57	12.54	12.51	12.48
6	12.45	12.41	12.38	12.35	12.32	12.29	12.26	12.23	12.20	12.17
7	12.14	12.11	12.08	12.05	12.02	11.99	11.96	11.93	11.90	11.87
8	11.84	11.81	11.79	11.76	11.73	11.70	11.67	11.64	11.62	11.59
9	11.56	11.53	11.51	11.48	11.45	11.42	11.40	11.37	11.34	11.32
10	11.29	11.26	11.24	11.21	11.18	11.16	11.13	11.11	11.08	11.06
11	11.03	11.00	10.98	10.95	10.93	10.90	10.88	10.85	10.83	10.81
12	10.78	10.76	10.73	10.71	10.68	10.66	10.64	10.61	10.59	10.56
13	10.54	10.52	10.49	10.47	10.45	10.42	10.40	10.38	10.36	10.33
14	10.31	10.29	10.27	10.24	10.22	10.20	10.18	10.15	10.13	10.11
15	10.08	10.06	10.04	10.02	10.00	9.98	9.96	9.94	9.92	9.90
16	9.87	9.85	9.83	9.81	9.79	9.77	9.75	9.73	9.71	9.69
17	9.66	9.64	9.62	9.60	9.58	9.56	9.54	9.52	9.50	9.49
18	9.47	9.45	9.43	9.41	9.39	9.37	9.36	9.34	9.32	9.30
19	9.28	9.26	9.24	9.22	9.21	9.19	9.17	9.15	9.13	9.11
20	9.09	9.08	9.06	9.04	9.02	8.01	8.99	8.97	8.95	8.93
21	8.91	8.89	8.87	8.86	8.85	8.83	8.81	8.80	8.78	8.76
22	8.74	8.73	8.71	8.69	8.68	8.66	8.64	8.63	8.61	8.60
23	8.58	8.56	8.55	8.53	8.51	8.50	8.48	8.47	8.45	8.43
24	8.42	8.40	8.39	8.37	8.36	8.34	8.32	8.31	8.29	8.28
25	8.26	8.25	8.23	8.22	8.20	8.19	8.17	8.16	8.14	8.13
26	8.11	8.10	8.08	8.07	8.05	8.04	8.02	8.01	7.99	7.98
27	7.97	7.95	7.94	7.92	7.91	7.89	7.88	7.87	7.85	7.84
28	7.83	7.81	7.80	7.78	7.77	7.76	7.74	7.73	7.71	7.70
29	7.69	7.67	7.66	7.65	7.63	7.62	7.61	7.59	7.58	7.57
30	7.56	7.54	7.53	7.52	7.50	7.49	7.48	7.46	7.45	7.44
31	7.44	7.44	7.43	7.42	7.41	7.39	7.38	7.37	7.36	7.35
32	7.33	7.32	7.31	7.30	7.29	7.28	7.26	7.25	7.24	7.23
33	7.22	7.21	7.19	7.18	7.17	7.16	7.15	7.14	7.13	7.11
34	7.10	7.09	7.08	7.07	7.06	7.05	7.04	7.03	7.01	7.00
35	6.99	6.98	6.97	6.96	6.95	6.94	6.93	6.92	6.90	6.89
36	6.82	6.81	6.80	6.78	6.77	6.76	6.75	6.74	6.73	6.72
37	6.71	6.70	6.69	6.68	6.67	6.66	6.65	6.64	6.63	6.62
38	6.61	6.60	6.59	6.58	6.57	6.56	6.55	6.54	6.53	6.52
39	6.51	6.50	6.49	6.48	6.47	6.46	6.45	6.44	6.43	6.42

Table A.1 continue

t °C	0	0.1	0.2	0.3	0.4	0.5	0.6	0.7	0.8	0.9
40	6.41	6.40	6.39	6.38	6.37	6.36	6.35	6.34	6.33	6.32
41	6.31	6.30	6.29	6.28	6.27	6.26	6.25	6.24	6.23	6.22
42	6.21	6.20	6.19	6.19	6.18	6.17	6.16	6.15	6.14	6.13
43	6.12	6.11	6.10	6.09	6.08	6.07	6.06	6.05	6.04	6.04
44	6.03	6.02	6.01	6.00	5.99	5.98	5.97	5.96	5.95	5.94
45	5.93	5.92	5.92	5.91	5.90	5.89	5.88	5.87	5.86	5.85
46	5.84	5.83	5.82	5.82	5.81	5.80	5.79	5.78	5.77	5.76
47	5.75	5.74	5.74	5.73	5.72	5.71	5.70	5.69	5.68	5.67
48	5.66	5.66	5.65	5.64	5.63	5.62	5.61	5.60	5.59	5.59
49	5.58	5.57	5.56	5.55	5.54	5.53	5.52	5.52	5.51	5.50
50	5.49	5.48	5.47	5.47	5.46	5.45	5.44	5.44	5.43	5.42